

DETAILS BORDURES

(Ech : 1/10)

BORDURE & PAVE:

TYPE: "GRANIT" ① BORDURE 2/20/23 TROTTOIR TRAVERSANT type "CROSSBORD" CB2
② PAVE 20/13/15

(ECH: 1/20)

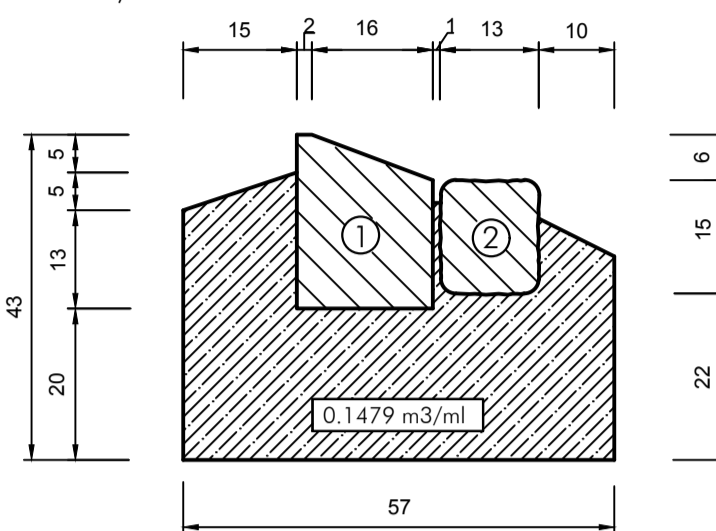

BORDURE & PAVE:

BORDURE GRANIT -> BORDURE TROTTOIR TRAVERSANT POUR RACCORD CONTINU type "CROSSBORD" CB1-G ou CB1-D + FILE DE PAVES GRANIT 20/13/15

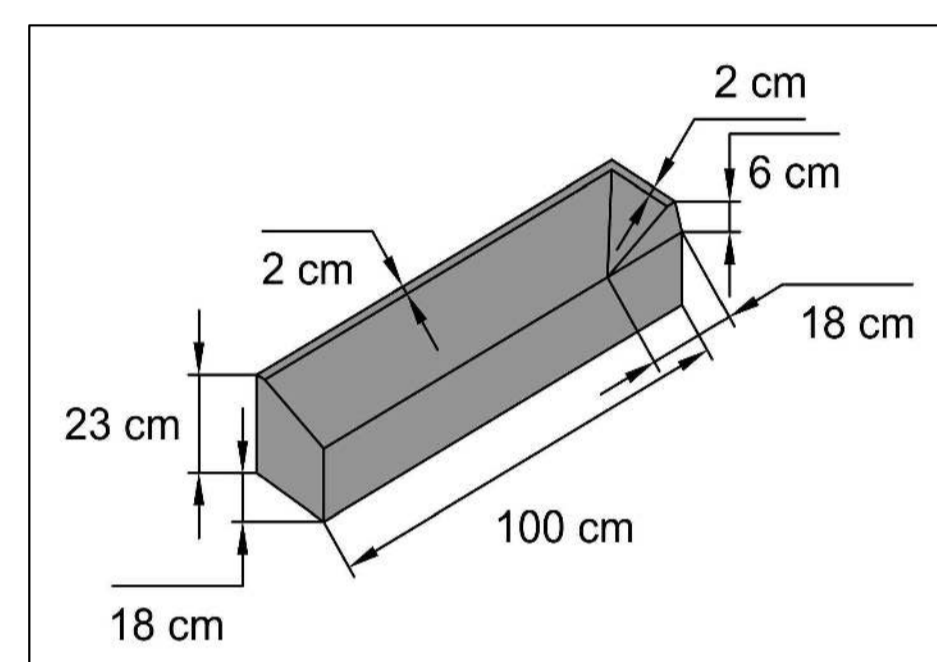

BORDURE & PAVE:

BORDURE GRANIT -> BORDURE TROTTOIR TRAVERSANT POUR RACCORD PERPENDICULAIRE type "CROSSBORD" CB3-G ou CB3-D + FILE DE PAVES GRANIT 20/13/15

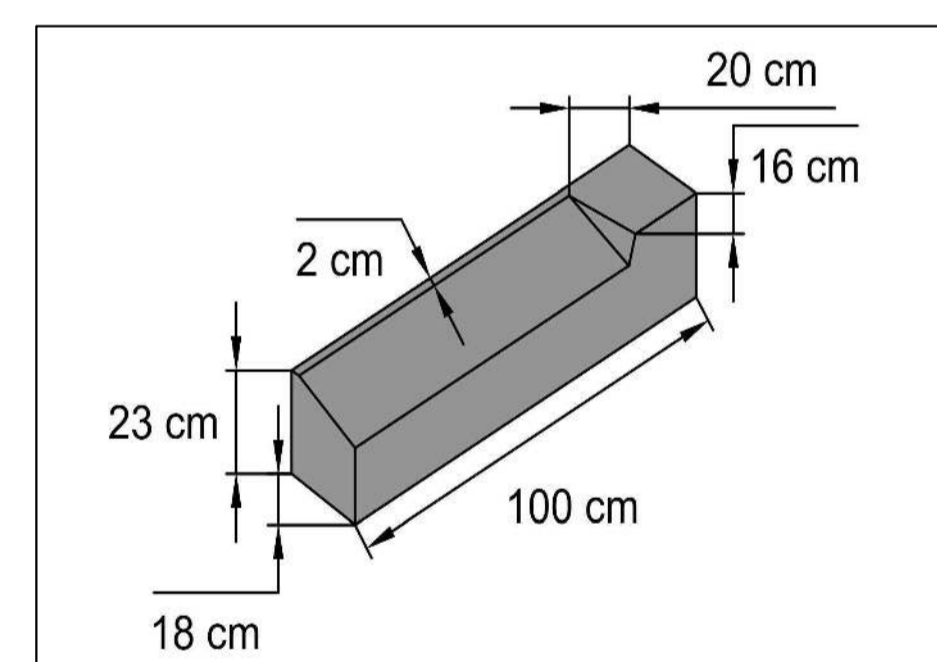

PHOTOS DE LA SITUATION EXISTANTE

(Sans échelle)



(1)

(2)

LEGENDE:

CHAUSSEE EN ENROBE :

- ① COUCHE DE ROULEMENT EN ENROBES BITUMEUX EB 11 R2 (ép : 5cm)
- ② COUCHE D'ACCROCHAGE A EMULSION EN BITUME
- ③ COUCHE DE LIAISON EN ENROBES BITUMEUX EB 16 L (ép : 5cm)
- ④ COUCHE DE LIAISON EN ENROBES BITUMEUX EB 16 L (ép : 5cm)
- ⑤ ENDUIT SUPERFICIEL MONOCOUCHE LHF 4/8
- ⑥ COUCHE DE BASE EN CONCASSE HF ou en QUARTZITE 0/45 TYPE "1" (ép: 20cm)
- ⑦ COUCHE DE FONDATION EN CONCASSE ou en QUARTZITE 0/45 TYPE "1" (ép: 20cm)
- ⑧ COUCHE DE FORME EN CONCASSE DE CARRIERE 0/45 "type 2" (ép : 25cm)
- ⑨ GEOTEXTILE 3 KJ/m²

TROTTOIR TRAVERSANT :

- ⑩ PAVES EN BETON (ép : 10 cm)
- ⑪ LIT DE POSE EN SABLE HF 0/4 (ép : 4 cm)
- ⑫ GEOTEXTILE 2 KJ / m2
- ⑬ COUCHE DE LIAISON EN ENROBES BBDr 16 L P (ép : 10 cm)
- ⑭ COUCHE DE BASE EN CONCASSE HF ou en QUARTZITE 0/45 TYPE "1" (ép: 15cm)
- ⑮ COUCHE DE FONDATION EN CONCASSE HF ou en QUARTZITE 0/45 TYPE "1" (ép: 16cm)
- ⑯ COUCHE DE FORME EN CONCASSE 0/45 TYPE "2" (ép:25cm)
- ⑰ GEOTEXTILE 3 KJ/m²

PAVÉS ET BORDURES :

- Ⓐ 1 FILE DE PAVES EN GRANIT 20/13/15
- Ⓑ BORDURE EN GRANIT GRISATRE 2/20/23
- Ⓒ BETON DE FONDATION C20/25 cat. 0 (XO)

COUPE TYPE A-A

(Ech : 1/50)

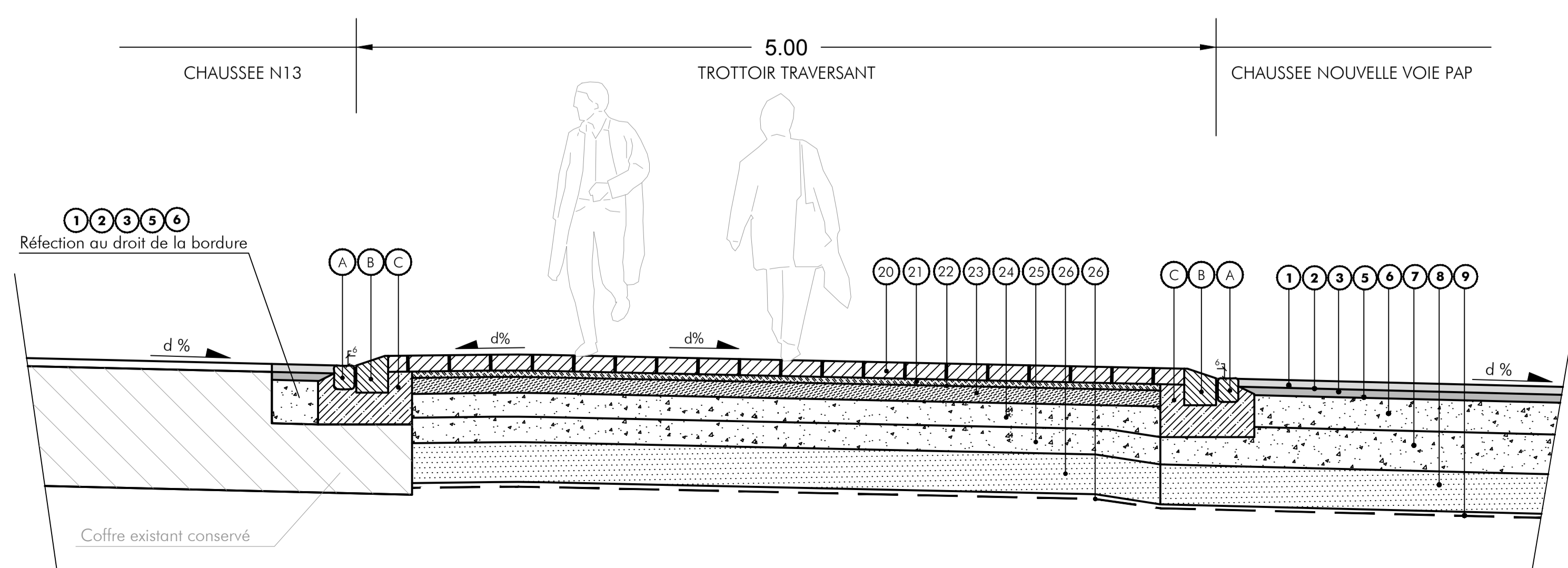

SITUATION

(Ech : 1/250)

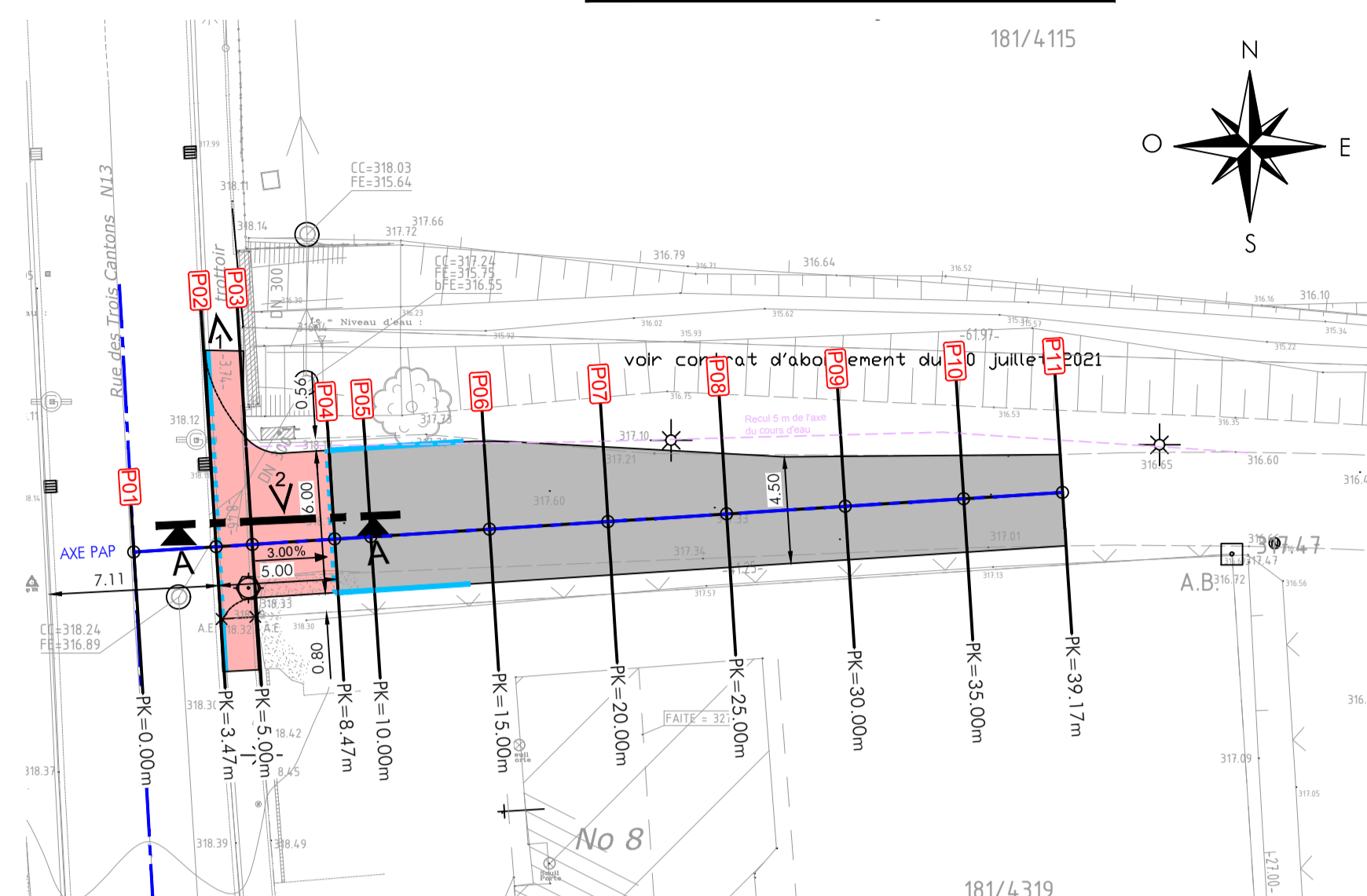

LEGENDE:

- Surface chaussée en enrobés
- Surface trottoir projeté (revêtement à déterminer)
- Espaces verts
- Bordure trottoir traversant (type "CROSSBORD" CB2) +6cm
- Bordure vue +6cm

CHAMPS DE VISIBILITES

(Ech : 1/500)

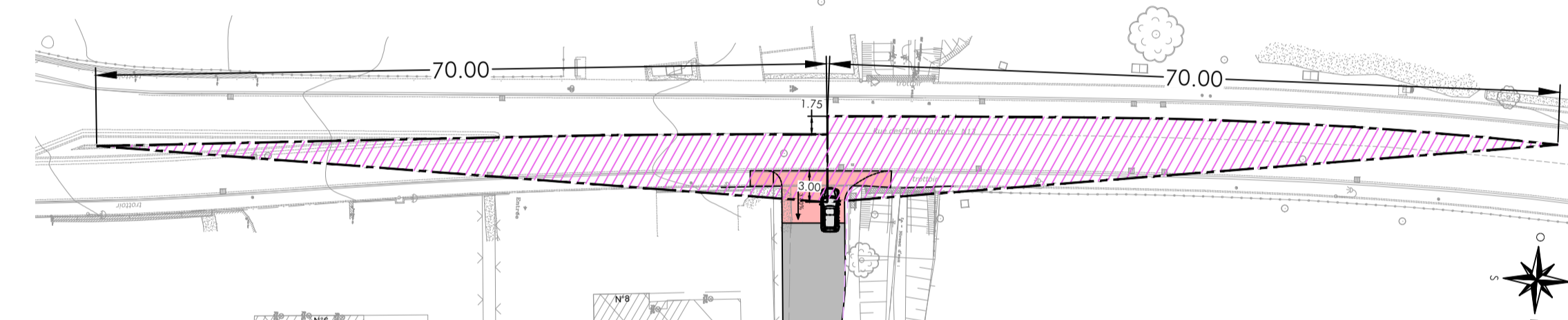

COURBES DE GIRATIONS

(Ech : 1/500)

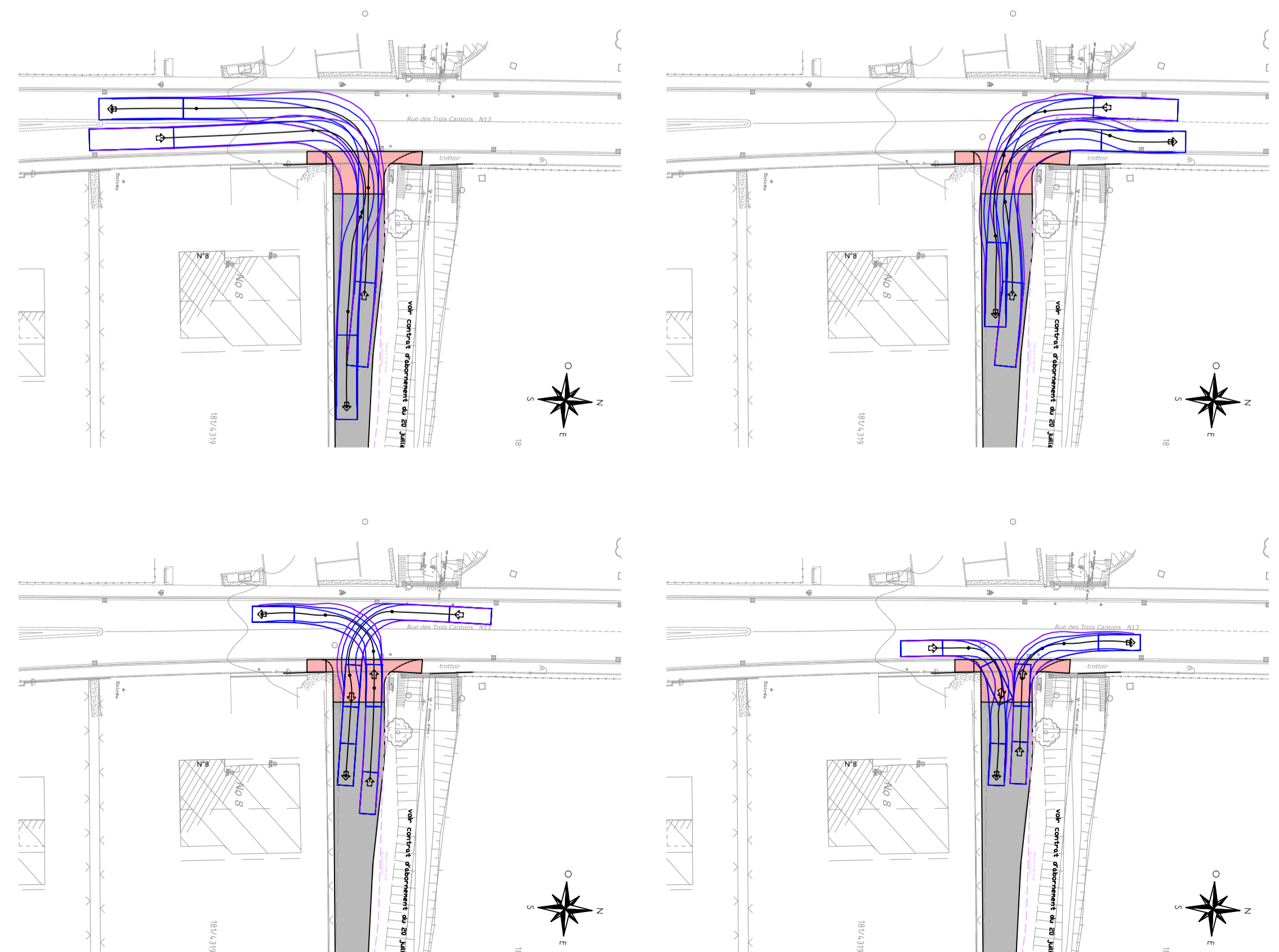

(Courbe de giration à 5 km/h)

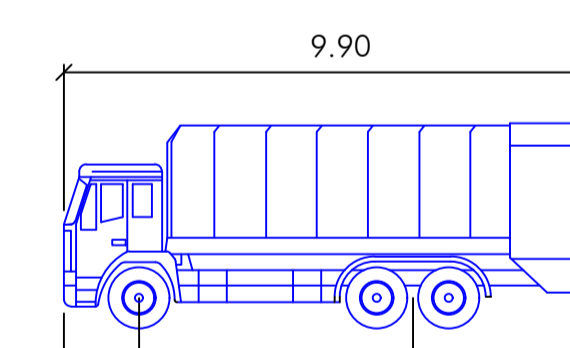

Camion à Ordures (9.90m)

mètres
 Largeur : 2.50
 Trace : 2.50
 Délai contre-bra. : 6.0
 Angle de braquage : 34.9

(Courbe de giration à 5 km/h)

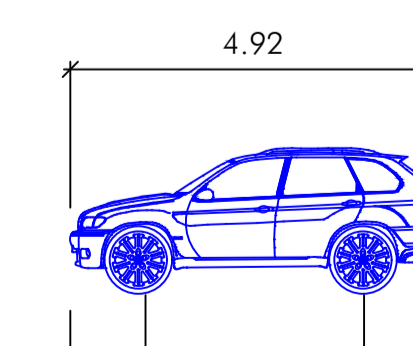

Grande Berline / SUV (4.92m)

mètres
 Largeur : 1.86
 Trace : 1.86
 Délai contre-bra. : 4.0
 Angle de braquage : 32.4

PROFIL EN LONG

(Ech X : 1/500 - Ech Y : 1/100)

Axe PAP

Echelle en X : 1/500

Echelle en Y : 1/100

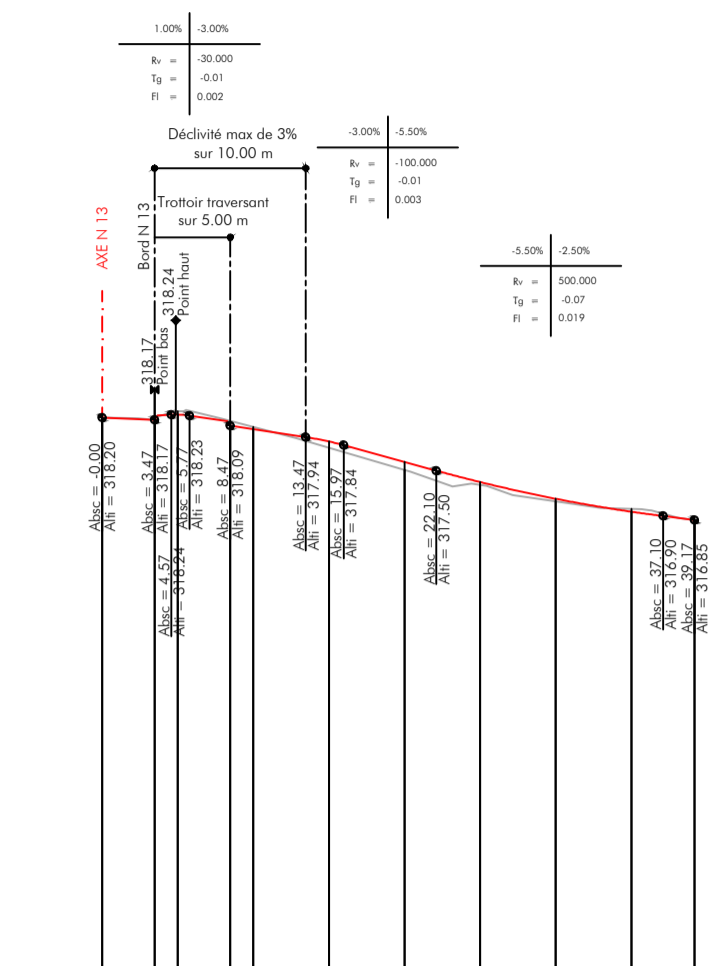

PC : 310.00 m

Numéro de profils en travers	P01	P02	P03	P04	P05	P06	P07	P08	P09	P10	P11																																															
Altitudes TN	318.20	318.20	318.20	318.20	318.20	318.20	318.20	318.20	318.20	318.20	318.20																																															
Altitudes Projet	318.20	318.20	318.24	318.24	318.25	318.25	318.25	318.25	318.25	318.25	318.25																																															
Ecartes TN - Projet	0.00	0.00	0.04	0.04	0.05	0.05	0.05	0.05	0.05	0.05	0.05																																															
Distances partielles Projet	3.47	3.47	5.00	5.00	5.00	5.00	5.00	5.00	5.00	4.17																																																
Distances cumulées Projet	0.00	3.47	6.94	11.94	16.94	21.94	26.94	31.94	36.94	41.11	45.28																																															
Pentes et rampes	<table border="1"> <thead> <tr> <th>Traverse</th> <th>Traverse</th> <th>PENTE</th> <th>Traverse</th> <th>Traverse</th> <th>Traverse</th> <th>Traverse</th> <th>Traverse</th> <th>Traverse</th> <th>Traverse</th> <th>Traverse</th> <th>Traverse</th> </tr> </thead> <tbody> <tr> <td>1</td> <td>2</td> <td>0.00</td> <td>3</td> <td>4</td> <td>5</td> <td>6</td> <td>7</td> <td>8</td> <td>9</td> <td>10</td> <td>11</td> </tr> <tr> <td>L = 3.00 m</td> <td>L = 3.00 m</td> <td>P = -5.50 ‰</td> <td>L = 3.00 m</td> <td>L = 3.00 m</td> <td>L = 3.00 m</td> <td>L = 3.00 m</td> <td>L = 3.00 m</td> <td>L = 3.00 m</td> <td>L = 3.00 m</td> <td>L = 3.00 m</td> <td>L = 3.00 m</td> </tr> <tr> <td colspan="11">RP = 500.00 L = 15.00</td> </tr> </tbody> </table>											Traverse	Traverse	PENTE	Traverse	Traverse	Traverse	Traverse	Traverse	Traverse	Traverse	Traverse	Traverse	1	2	0.00	3	4	5	6	7	8	9	10	11	L = 3.00 m	L = 3.00 m	P = -5.50 ‰	L = 3.00 m	L = 3.00 m	L = 3.00 m	L = 3.00 m	L = 3.00 m	L = 3.00 m	L = 3.00 m	L = 3.00 m	L = 3.00 m	RP = 500.00 L = 15.00										
Traverse	Traverse	PENTE	Traverse	Traverse	Traverse	Traverse	Traverse	Traverse	Traverse	Traverse	Traverse																																															
1	2	0.00	3	4	5	6	7	8	9	10	11																																															
L = 3.00 m	L = 3.00 m	P = -5.50 ‰	L = 3.00 m	L = 3.00 m	L = 3.00 m	L = 3.00 m	L = 3.00 m	L = 3.00 m	L = 3.00 m	L = 3.00 m	L = 3.00 m																																															
RP = 500.00 L = 15.00																																																										
Alignements droits et courbes	DROITE L = 30.17 m																																																									

Localisation

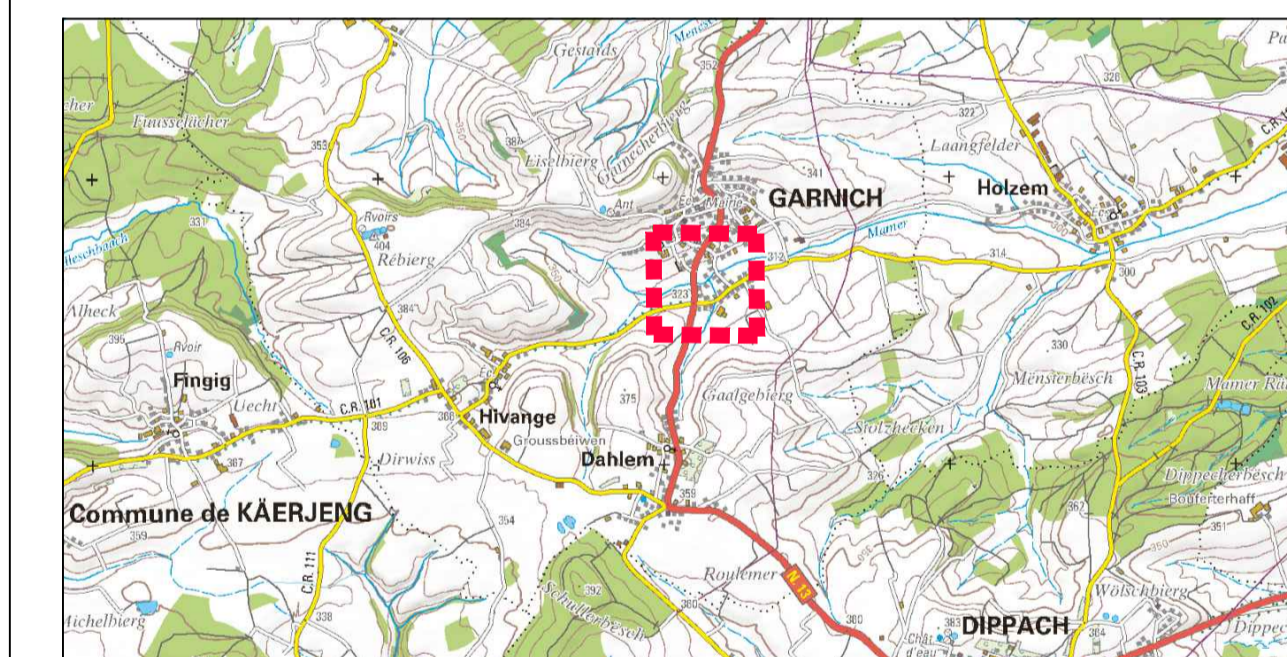

AUTORISATION

FONDS DE PLAN : © ORIGINE CADASTRE. DROITS RESERVES A L'ETAT DU GRAND DUCHÉ DE LUXEMBOURG - COPIE ET REPRODUCTION INTERDITES

MAITRE D'OUVRAGE:

PIMANTE S.A.R.L

PROJET: **PAP Route des 3 Cantons à Garnich Raccordement sur N13**

OBJET: **PERMISSION DE VOIRIE SITUATION / GIRATIONS / CHAMPS DE VISIBILITÉ / COUPE-TYPE / PROFIL EN LONG**

IND	DATE	DESIGNÉ	CONTRÔLE	VALIDÉ	MODIFICATIONS
E		INITIALE	VISA	INITIALE	VISA
D					
C					
B					
A					

	ÉCHELLE	N° PROJET	N° PLAN	INDICE					
/	04/11/2021	M.F.R.	M.P.	J.P.K.	J.P.K.	Variable	V215343	VRD_AUT_PMV-001	/

Tel.: (+352) 49 00 65 1
 e-mail: tr-engineering.lu
 86-88, rue de l'Égalité
 BP 1034
 L-1010 Luxembourg

TR ENGINEERING
ingénieurs-conseils